

TOP VIEW

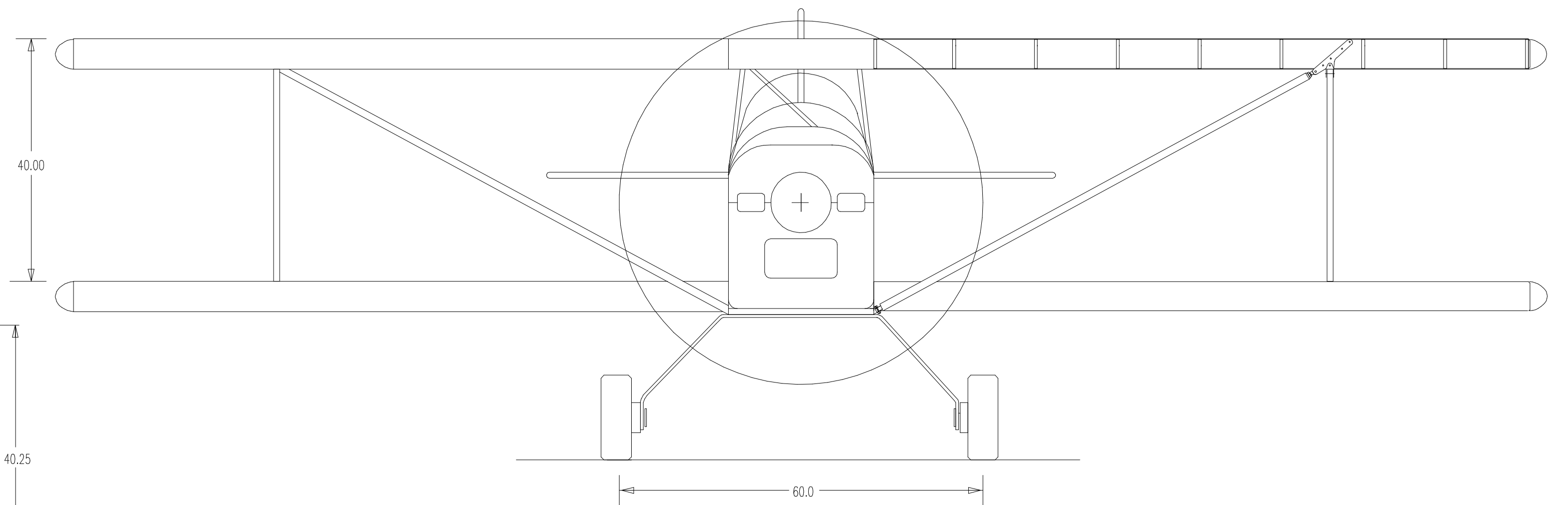

FRONT VIEW

SPECIFICATIONS	
WING SPAN	20.0 FT.
WING AREA	133 SQ. FT.
GROSS WEIGHT	800 LBS.
EMPTY WEIGHT	500 LBS.
OVERALL LENGTH	17 FT.
HEIGHT	6 FT.
ENGINE	80 HP.
TOP SPEED	130 MPH.
CRUISE SPEED	110 MPH.
STALL SPEED	45 MPH.
PROPELLER	68 X 48

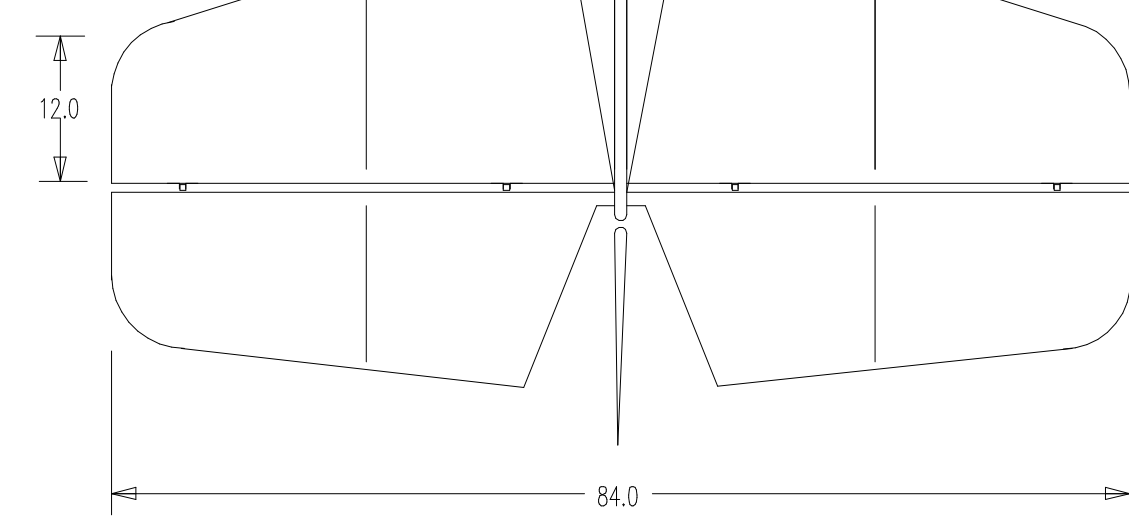
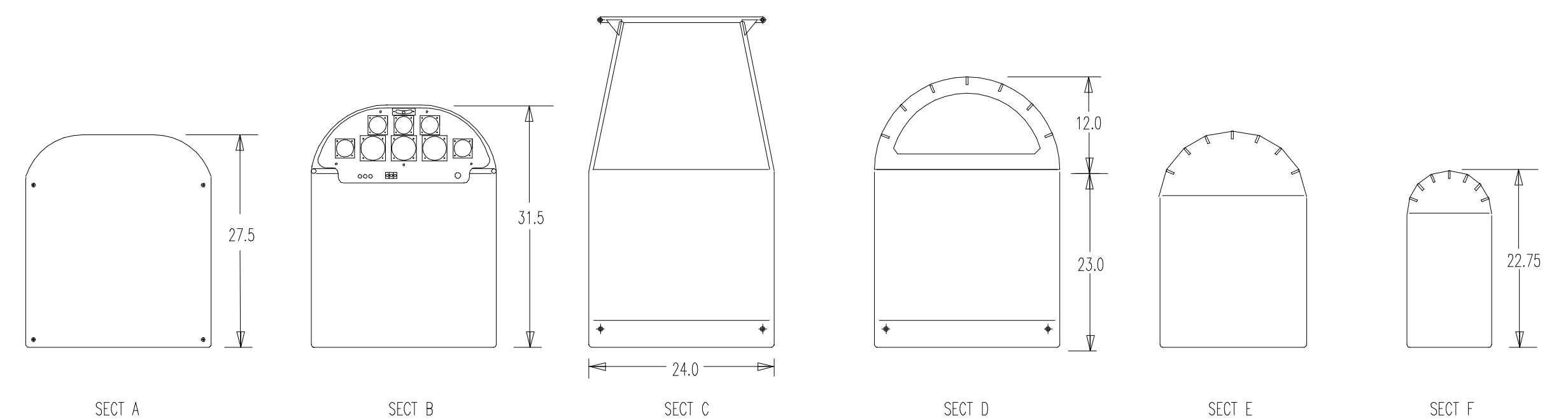

FUSELAGE SECTIONS

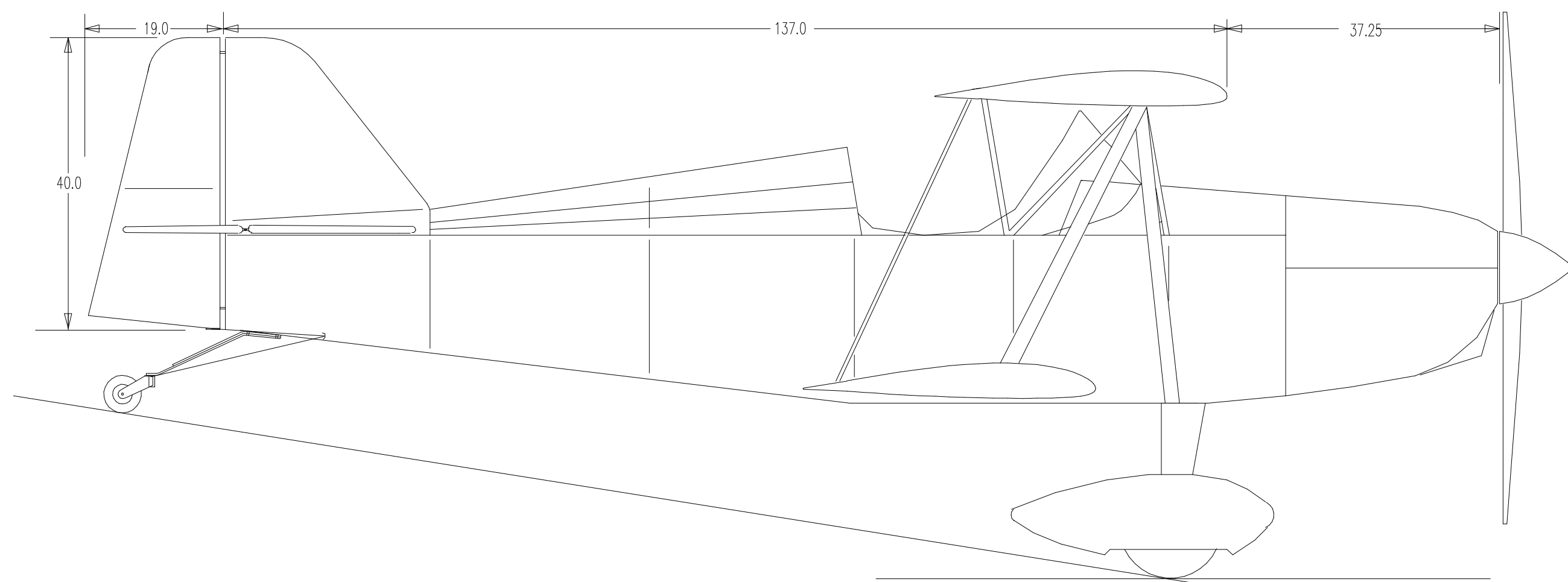

RIGHT SIDE VIEW

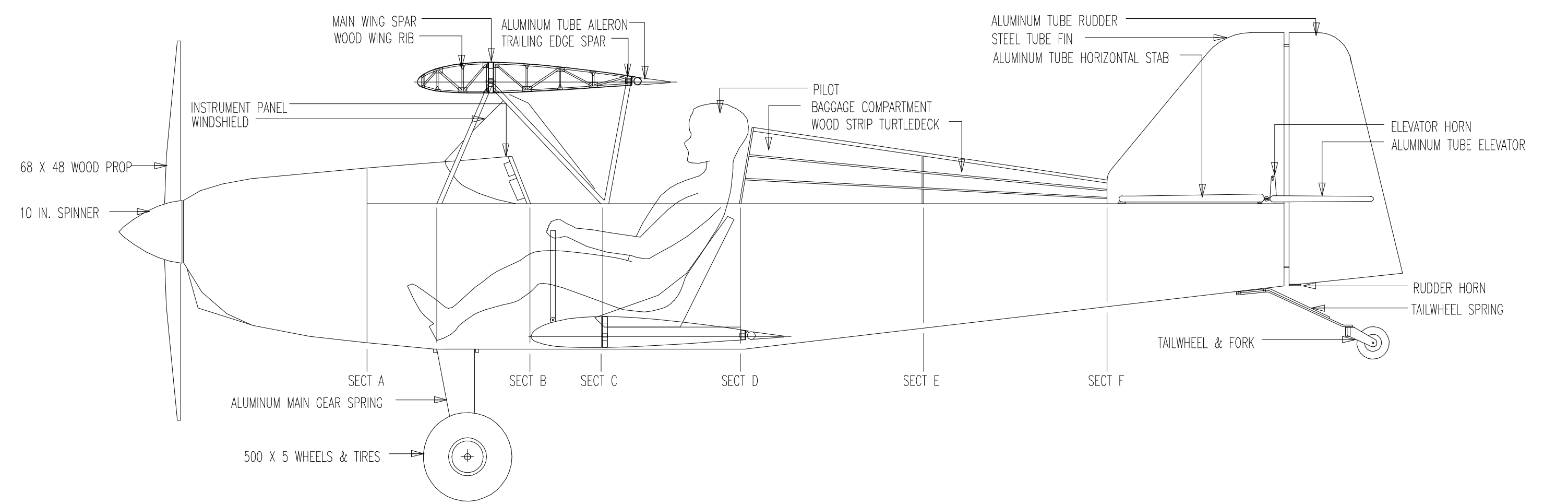

LEFT SIDE CUTAWAY VIEW

ACROLITE BIPLANE		DRAWING NO.	0
3 VIEW & SECTIONS FOR MODEL BUILDERS		MODEL	1B
		SERIAL NO.	
		SCALE	1/16
DRN. BY	RON WILSON	REV.	12/12/96
		DATE	10/10/94