

SPECIFICATIONS	
WING SPAN	18.1 FT.
WING AREA	111 SQ. FT.
GROSS WEIGHT	700 LBS.
EMPTY WEIGHT	450 LBS.
OVERALL LENGTH	16.75 FT.
HEIGHT	6.0 FT.
ENGINE	50 HP.
TOP SPEED	95 MPH.
CRUISE SPEED	80 MPH.
STALL SPEED	44 MPH.
GLIDE RATIO	7 TO 1
RATE OF CLIMB	900 FPM.
PROPELLER	64 X 42
LOAD LIMIT	+6 -4 G.

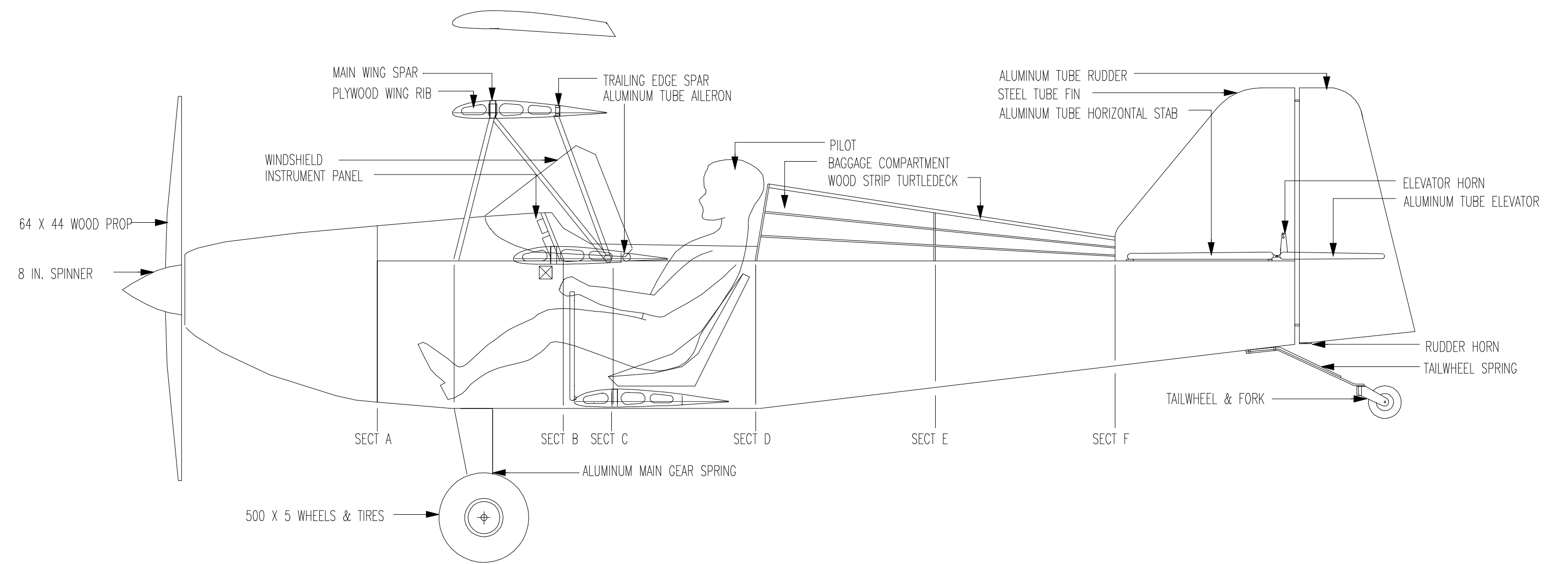
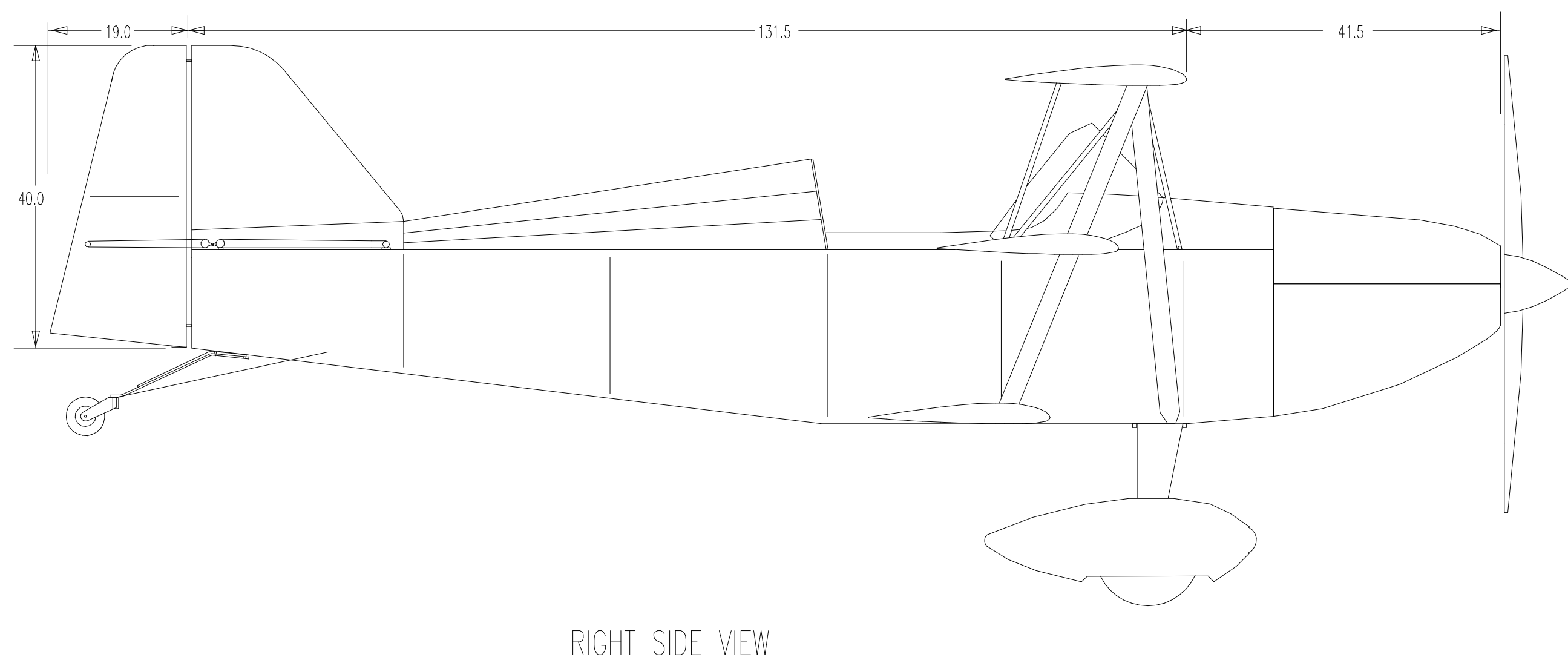
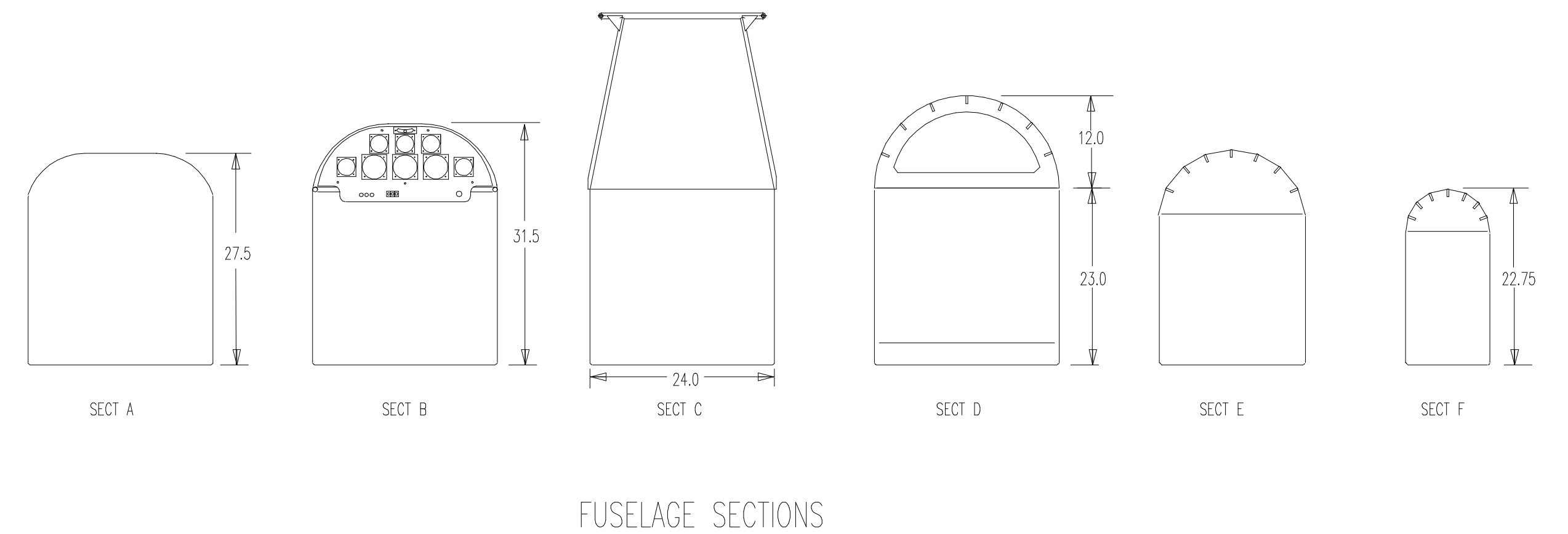

ACROLITE TRIPLANE		DRAWING NO.	1
3 VIEW & SECTIONS FOR MODEL BUILDERS		MODEL	1T
		SERIAL NO.	
		SCALE	1/16
DRN. BY	RON WILSON	REV.	08/08/01
		DATE	05/05/00